



Hartau Series

Hartau Triple

Design by Alexandre Joncas

The Hartau series brings together classical light fittings that are, at first glance, astonishing in their line and detail. They have been handmade in Canada using frosted glass, brass, and painted aluminium.

The lampshades are the signature of this collection: with their two openings they offer both direct and indirect light to the wall or the ceiling. Each metal part of the Hartau collection is precision made in Quebec, Canada.

J. Joncas

HARTAU triple

Design by Alexandre Joncas

ø 12.7 cm
ø 5 in

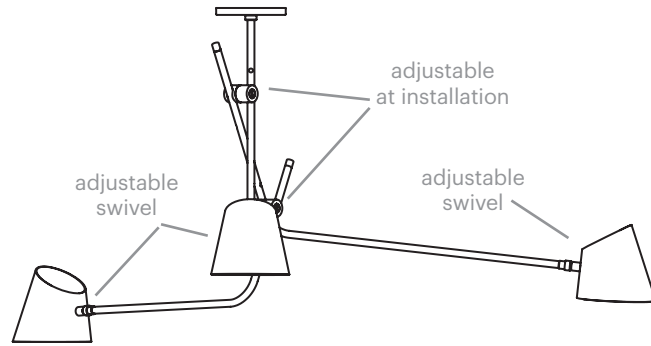

min 64 cm
min 25 in

107 cm
42 in

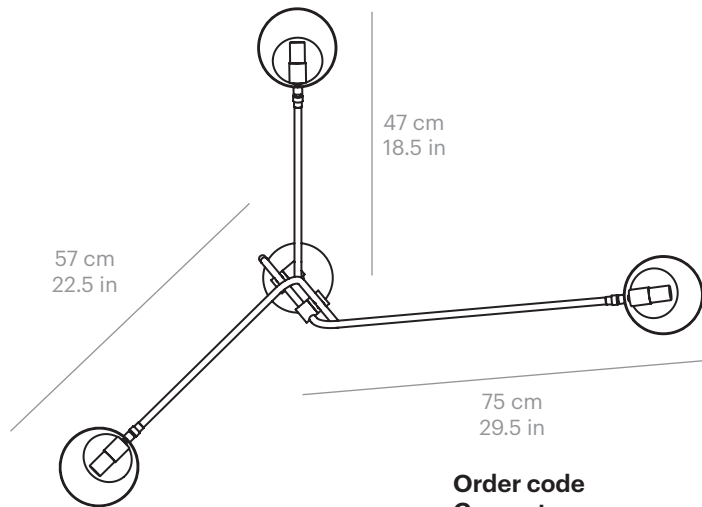

47 cm
18.5 in

57 cm
22.5 in

75 cm
29.5 in

Lamping Specifications

Input voltage : 120V or 220-240V
Power input : 15W
Technology : G9 LED bulb (included)
CRI : >90
CCT : 2700K (Warm white)
Lumen source : 1050 lm

Product Weight

1.8 kg / 4.2 lbs

Height





A	B	C	D
64 cm / 25 in	89 cm / 35 in	112 cm / 44 in	201 cm / 79 in

*custom height available upon request

Certifications

IP20  

Materials

- | | |
|--|--|
|  Available Finish : |  Swivel & details : |
|  Matt black |  Polished brass |
|  Matt white |  Chrome plated |
|  Grey gloss |  Black oxidized |
|  Chrome plated | |
|  Custom | |

Order code Generator

Series	Model	Finish	Details	Voltage	Height	QTY
HA Hartau	TR Triple	BL Matt black	BR Polished brass	1 120V	A 64 cm	.
.	.	WH Matt white	OX Black oxidized	2 220-240V	B 89 cm	.
.	.	WG Grey gloss	CH Chrome	.	C 112 cm	.
.	.	CH Chrome	.	.	D 201 cm	.
.	.	ZZ Custom	.	.	Z Custom	.
Order code :	HA	TR	—	—	—	-

